

Ruko[®]

14+
for age

Quick Start Guide

v3.0

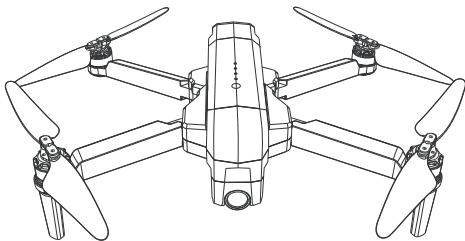

F11PRO

CONTACT US FOR MORE TECH SUPPORT



+ 1 (888)892-0155 | Mon-Fri 7:00AM - 7:00PM (PST)



rukotoy.com



CONTACT US FOR MORE TECH SUPPORT



+1 (888)892-0155 | Mon-Fri 7:00AM - 7:00PM (PST)



+86 19129317359



1

Download App



Charge the Batteries

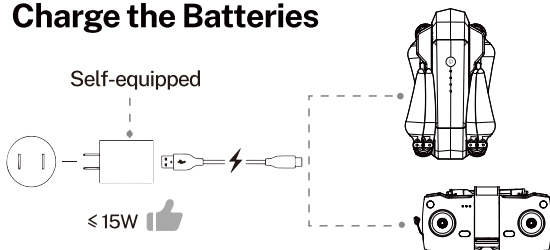

2

Unfold the Arms

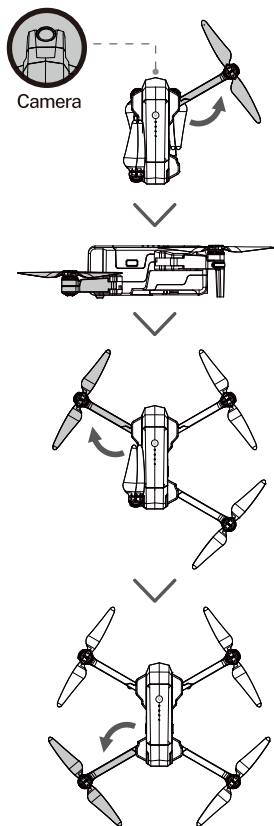

3

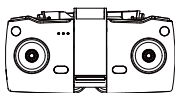

Unfold the antenna

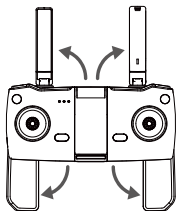

Unfold the handle

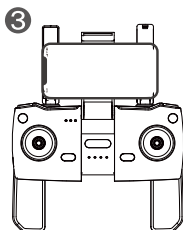
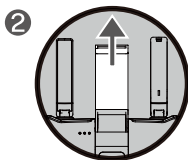
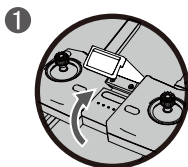

4

Select an Open Flight

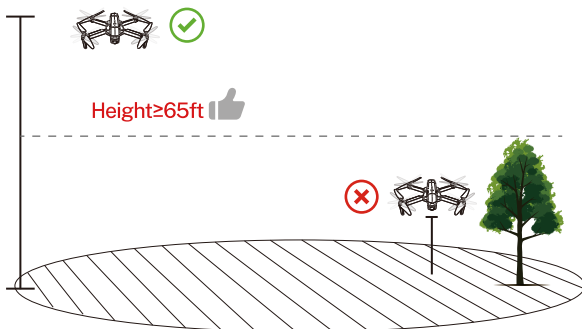

5

1

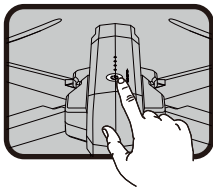

- Press and hold the button until the Aircraft plays startup sound.

2

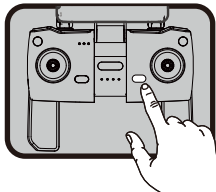

- Short-press to power on the Transmitter.

Pair the Transmitter with the Aircraft

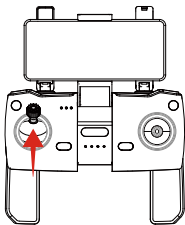

- Push up the left stick and the Transmitter plays a sound "di".

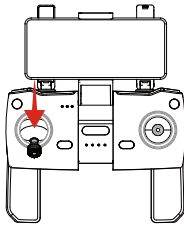

- Push down the left stick and the Transmitter plays another sound "di".

⚠ Once successfully paired, white light will stay on.

6

Connect to Wi-Fi

- Connect the mobile device to the Aircraft's Wi-Fi and enter the App operation page. Please refer to User Manual (page 36) for more details.

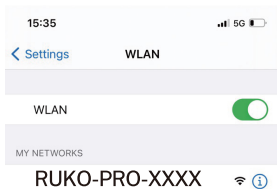

Tap "CONTROLS" icon

Calibrate the Compass

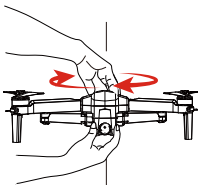

- Rotate the aircraft horizontally 360°. (About 1-2 turns)

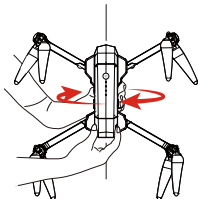

- Rotate the aircraft vertically 360°. (About 1-2 turns)

7

Calibrate the Gyroscope

- Push joysticks to 11 & 1 o'clock position.
(About 2 seconds)

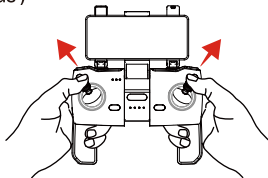

Start the Motors

- Push joysticks to 5 & 7 o'clock position.
(About 2 seconds)

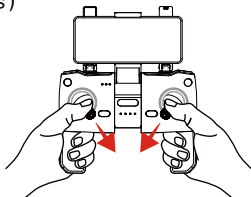

Take off

- Push up the left stick or press the "Auto Takeoff" button.

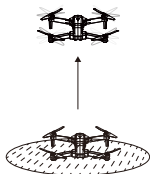
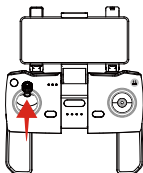



NEW TO FLYING DRONES?

Check the Flight Guide in the App



Search “**Ruko F11 Pro Quick Start**” on YouTube for First Flight

Scan QR Code for More Tech and Video Support

CONTACT US FOR MORE TECH SUPPORT

Printed in China.

Common Problems and Solutions

Question	Reason	Solutions
The motors cannot be started	Weak GPS signal	Turn on the Aircraft in an open area with strong GPS signal
	The red light stays on	The Aircraft has low battery. Please charge the battery in time
	The pink light stays on	The compass is not calibrated. Please refer to the "Calibration Before Flight" section of the user manual
	The left and right joysticks are not in place	Push the left and right joysticks simultaneously to 5 o'clock and 7 o'clock for 2 seconds
Unstable flight	Flying too low, affected by Aircraft airflow	Please fly the Aircraft above 9.84ft(3 meters)
	The gyroscope is not calibrated	Place the Aircraft on a horizontal surface and conduct gyroscope/horizontal calibration. Please refer to the "Calibration Before Flight" section of the user manual
	The propellers become deformed and incomplete	Replace the propellers with new ones
	GPS signal is unstable. Flying near buildings and in obstructed places	Please fly the Aircraft in an open area free of obstacles within the circle of radius 32.81 ft(10 meters)
The product has slight marks	We tested all Aircraft before shipping	In order to give you the best experience, we tested functions of all Aircraft before shipping. Therefore, it is inevitable that there will be slight traces. However, it can be guaranteed that all Aircraft are 100% brand new

Question	Reason	Solutions
Out of control, spinning around on its own, abnormal sound	The Transmitter signal is interfered or the Aircraft exceeds the range of remote control	Please fly the Aircraft outdoors without interference, and ensure that it is within a controllable range
	Compass interference	Please manually land the drone in time and calibrate the compass. Please make sure to fly away from the buildings, trees, power lines, and signal towers
	The propellers become deformed and incomplete	Replace the propellers with new ones
The camera is tilted/Gimbal is not working/ Can't adjust the camera angle	The drone was placed on an unlevel surface such as grass and sand and so on	Place the drone on landing pad or cardboard horizontally, and ensure a gap between the camera and the surface
	The drone was placed on the surface which transfer small vibration, such as hollow wooden floor, desk and so on	Place the drone on a solid level ground
	Keep touching the camera and gimbal or holding the drone before all set	Never touch the camera when the power is on, place the drone on a level ground until the gimbal complete self-check
	The compass is in calibrating	After complete the compass calibration, place the drone on a level ground
Short battery life	Flying in windy weather	Flying in windy weather will accelerate power loss
	Flying in cold weather	In low temperatures, the chemical reaction of the lithium battery is slowed down and the energy cannot be fully released
	The battery is not fully charged	Fully charged with the correct USB charger before flying

Question	Reason	Solutions
Video freezes, image transmission distance is short	The Aircraft is out of Wi-Fi range	Fly the Aircraft within the range of the Wi-Fi
	WiFi image transmission signal interference	Fly the Aircraft in an unobstructed open area free of buildings, high-voltage wires and signal towers
	The transmitter and the mobile phone are not pointed at the direction of the drone	Point the Transmitter and the mobile device at the flying direction of the Aircraft to maintain the strongest signal connection
	Phone performance freezes	Close unused apps running in the background to maintain the best performance of the phone
Video is not clear	if use APP storage, the pixels are 1920×720P	Insert the memory card and storage the video on the memory card
App does not show what the drone's camera is taking	The phone is not connected to the drone's Wi-Fi	Connect the drone's Wi-Fi : Ruko-GIM-***** on the phone
	The phone operating system version is too low	The required device operating system to work with the app is Android 6.0 and above, IOS 10.02 and above
	Certain phones' setting preventing the app working normally	Set the phone to airplane mode
	The VPN app block the connection of the phone and the drone	Turn off the VPN
	Didn't keep the drone's network when trying to connect the drone's WiFi	Please do keep the drone's WiFi connected when the phone pop up reminder that "This network has no internet access"

Question	Reason	Solutions
APP crashes or functions abnormally	Wrong app downloaded	Download the correct App
	A few mobile phone versions are old and incompatible with APP	Provide mobile phone version and model, we will adapt and solve it
Phone cannot connect to the drone's Wi-Fi	It will take longer time for certain phone to connect with the drone's Wi-Fi for the first time	Try several times or restart the phone
The drone's WiFi name is not displayed in the list	WiFi has not been activated	The WiFi will be available when the drone and the transmitter connected, which take around 40 seconds
GPS signal is weak	Turning on the drone indoors	GPS signals cannot be found indoors. Please search for GPS signals in an open place outdoors
	Under the tree, next to the building, in an obstructed place	Please stay away from obstacles for more than 32.81 feet(10 meters), and search for GPS signals in an open area
Unable to return home, drifting and flying away	GPS signal was turned off during the flight	Please don't turn off GPS suddenly during outdoor flight. Switch back to GPS mode in time
Cannot charge battery/Cannot fully charge battery	Using inferior charger or charging on the computer with unstable voltage output	Use a mobile USB charger that ensures constant stable voltage output(5V) and amperage output(2-3A)
	Using inferior charging cables	Please use the original factory charging cable to charge

Ruko Tech Support
<https://rukotoy.com/support-drones>

This User Manual is subject to change without notice.

You can check the recently updated version of "User Manual" on Ruko's official website
<https://rukotoy.com/support-drones>

If you have any questions or suggestions about the User Manual, please contact us via the following email:
rukodrone@gmail.com

Ruko is a trademark of Shenzhen Ruike Innovation Technology Co.,Ltd
Copyright 2022 Ruko All Rights Reserved.

Ruko[®]

rukotoy.com

CONTACT US FOR MORE TECH SUPPORT

 + 1 949-394-4635 | Mon-Sun 6PM-4AM(PST)

 +86 19129317359

 rukodrone@gmail.com

